

Spring 2006

## Energy Savings through Optimized Refining

Energy costs continue to soar making energy reduction the hottest topic in papermaking. At TAPPI's 2006 Papermakers Conference held April 24-27 in Atlanta, Georgia, energy reduction was a common theme. It comes as no surprise, discussions covered stock prep refining, one of the greatest areas of electrical energy use in the papermill, typically following only papermachine drives and vacuum systems. Shawn Berg, J&L Applications Manager, presented a paper on "Energy Savings through Optimized Refining".

An efficient refining system can have a tremendous impact on reducing the electrical energy which is an important component of a mill's cost structure. Opportunities for energy savings in refining can be accomplished in many ways, with little or no capital investment. The first step is a refiner checkup or audit. Energy savings of 10% or more can be found through optimization of patterns, alloys, and refiner configuration. Proper mechanical condition of the refiner is crucial for efficient refining and energy conservation. Mechanical audits should be performed annually to minimize wasted energy. Listed below are some of the ways J&L Fiber Services can help you save energy in your refining system.

### Underhung Plate Designs

The use of underhung or cutback plate designs will reduce the "No Load" energy of your refiners by decreasing the effective diameter of the refiner plate. By matching flow rates through the refiner to the optimum plate diameter, savings of 5-10% of the total energy applied can be conserved. For a 42" diameter refiner this can be \$30,000 to \$50,000 per year in electrical energy savings.

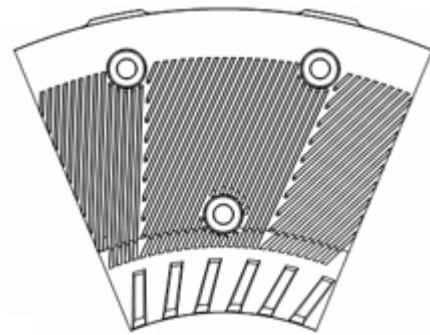

In addition, if the refiners are operating below the proper flow range with a standard diameter pattern, installing an underhung pattern can greatly improve the efficiency of refining and lead to a reduction in the HPD/T required.

### C90 Alloy for Improved Efficiency

The selection of the proper alloy can result in energy savings due to maintaining a sharp bar edge. J&L's C90 alloy develops a "raised bar edge" unlike any other

Sharp bar edges catch the fibers more easily and create a pad on the bar edge for maximum energy transfer to the fiber. Fiber development can even improve as the plates wear to create a concave bar surface as shown in the picture to the right. When comparing C90 alloy to a High Carbon Stainless



Steel (HCSS), the tensile strength development actually increases over time with C90, while the bar edge rounding causes the tensile development to drop off after the first two weeks of plate life for the HCSS. To maintain fiber development, a plate with rounded bar edges requires higher energy loads. Energy savings can be realized with C90 alloy by maintaining the same energy requirement for the life of the plate.

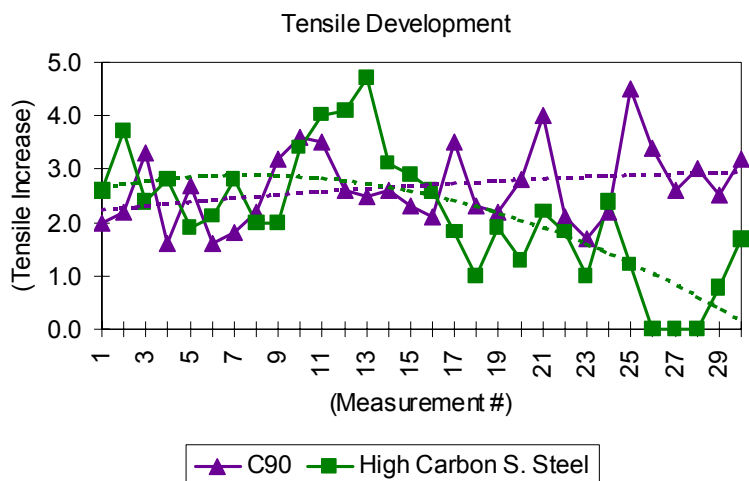

**Importance of Mechanical Condition**

The mechanical condition of a refiner greatly affects energy use. Some causes of wasted energy are worn packing sleeves, over-greased couplings, packing gland issues, and run-out or tram alignment problems. In addition, a poorly floating rotor can typically consume about 10% more energy than if the rotor was floating properly, alignment issues can cause significant amounts of energy to be wasted as the plates must wear in before efficient refining can occur, and rotor runout is even worse as the plates cannot “wear in”. These issues will result in higher specific energy being required to achieve the desired strength properties.

To maintain maximum refining efficiency, annual refiner audits should be performed and are available from J&L free of charge. Mechanical audits of refiners can identify the extent of mechanical inefficiencies. Once identified, the decision to recondition or rebuild a refiner can be weighed against the cost of replacement. With rising energy costs, the justification for refiner rebuilds is often money well spent.

**Floating Rotor Upgrades**

In addition to restoring refiner condition and minimizing no load losses with a rebuild, new technology has improved the efficiency of refining by more uniformly developing the fiber. Upgrading from a standard floating shaft to a floating rotor can improve refining efficiency and have added benefits such as longer plate life and lower maintenance costs. A second upgrade that exists with a floating rotor

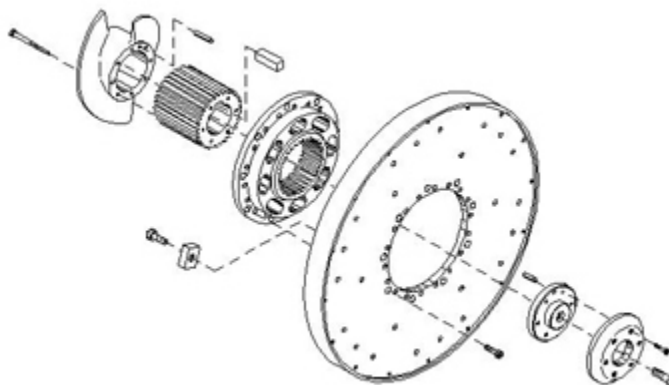

upgrade is the addition of a Turbulator. The Turbulator is available for Beloit refiner upgrades and

creates a balanced stock flow to both sides of the rotor under a greater range of conditions and can significantly improve refining efficiency.

***To request a copy of the complete paper and presentation on “Energy Savings through Optimized Refining”, email Shawn Berg at [srberg@jlfiberservices.com](mailto:srberg@jlfiberservices.com).***

***To discuss energy saving opportunities within your refiner system, contact your J&L sales representative.***

**J&L Fiber Services, Inc.**

809 Philip Drive

Waukesha, Wisconsin 53186

U.S.A.

Phone: 262-544-1890

Fax: 262-547-8166

[www.jlfiberservices.com](http://www.jlfiberservices.com)

© 2006 J&L Fiber Services, Inc.